

Equipment P/N:
610007AB

Issue: L

Ground Instruction Manual



Equipment P/N:
61007AB

Issue: L

Ground Instruction Manual



Acceptance and Signature

	Company	Name	Department	Date	Telephone	Signature
Prepared	FLEXIM	Kraft	R&D	11/12/2017	+49 (30) 936 676 60	<i>K. Kraft</i>
Checked	FLEXIM	Buschmann	R&D	11/12/2017	+49 (30) 936 676 60	<i>Buschmann</i>
Accepted	Airbus	Wittenbrock	SEMS1	<i>17.12.2017</i>	+49 (421) 538 5842	<i>Wittenbrock</i>

Record of Revision

Issue	Date	Page affected	Reason for Revision
A	10/01/2007	All	First Issue
B	04/04/2007	7	Updated "Table of contents".
		28	Rephrased sentence.
		33	Added note: "Troubleshooter mode" Rephrased note: "Connect sensor!"
		34	Added paragraph.
		35	Changed format.
		38	Added paragraph.
		45 - 49	Added new chapter "Troubleshooter mode".
C	23/09/2008	59	Changed format.
		61	Updated "Index".
		21	Rephrased sentence.
		44	Changed display and paragraph.
		53	Rephrased sentence.
D	18/05/2010	55	Changed part number.
		61	Updated "Index".
		13	Updated calibration procedure.
		61	Updated "Index".
		7	Updated "Table of contents".
E	16/11/2010	9	Removed paragraph. Added tables.
		34	Added table.
		51	Added tables.
		55	Added part number.
		61	Updated "Index".

Continued on next page

Ground Instruction Manual



Issue	Date	Page affected	Reason for Revision
F	22/08/2012	7	Updated "Table of contents".
		10	Changed caption. Changed letter ($\Delta T \rightarrow \Delta t$).
		17	Changed picture.
		55	Changed part number.
		61	Updated "Index".
G	17/12/2014	10	Added table.
		34	Added table.
		47	Added paragraph.
		48	Added table.
		51	Added table.
		55	Added part number.
H	21/08/2015	59 - 60	Updated "Declaration of Conformity".
I	23/03/2016	59 - 60	Updated "Declaration of Conformity".
J	20/05/2016	7	Updated "Table of contents".
		10	Changed table, added table.
		36	Changed table, added table.
		40	Changed paragraph.
		41	Added paragraph.
		53 - 54	Changed table, added table.
		57	Added part number.
		63	Updated "Index".
K	02/06/2017	17	Changed value for battery capacity (Ah).
		29	Rephrased sentence.
		57	Changed value for battery capacity (Ah).
L	11/12/2017	1	Changed address (street name).
		15	Changed paragraph.
		19	Removed "Battery compartment" label.
		25	Rephrased sentence.
		29	Changed table text. Added note.
		30	Changed "Power Supply" section.
		43	Deleted "Caution!" note.
		55	Changed address (street name).
		61 - 62	Updated "EU declaration of conformity".



List of Effective Pages

Page	Issue	Rev.-Date
1	L	11/12/2017
2	A	10/01/2007
3	A	10/01/2007
4	J	20/05/2016
5	J	20/05/2016
6	A	10/01/2007
7	J	20/05/2016
8	J	20/05/2016
9	J	20/05/2016
10	J	20/05/2016
11	J	20/05/2016
12	J	20/05/2016
13	J	20/05/2016
14	J	20/05/2016
15	L	11/12/2017
16	J	20/05/2016
17	K	02/06/2017
18	J	20/05/2016
19	L	11/12/2017
20	J	20/05/2016
21	J	20/05/2016
22	J	20/05/2016
23	J	20/05/2016
24	J	20/05/2016
25	L	11/12/2017
26	J	20/05/2016
27	J	20/05/2016
28	J	20/05/2016
29	L	11/12/2017
30	L	11/12/2017
31	J	20/05/2016
32	J	20/05/2016
33	J	20/05/2016
34	J	20/05/2016
35	J	20/05/2016
36	J	20/05/2016
37	J	20/05/2016
38	J	20/05/2016
39	J	20/05/2016
40	J	20/05/2016

Continued on next page

Equipment P/N:
610007AB

Issue: L

Ground Instruction Manual



Page	Issue	Rev.-Date
41	J	20/05/2016
42	J	20/05/2016
43	L	11/12/2017
44	J	20/05/2016
45	J	20/05/2016
46	J	20/05/2016
47	J	20/05/2016
48	J	20/05/2016
49	J	20/05/2016
50	J	20/05/2016
51	J	20/05/2016
52	J	20/05/2016
53	J	20/05/2016
54	J	20/05/2016
55	L	11/12/2017
56	J	20/05/2016
57	K	02/06/2017
58	J	20/05/2016
59	J	20/05/2016
60	J	20/05/2016
61	L	11/12/2017
62	L	11/12/2017
63	J	20/05/2016



Table of Contents

1	GENERAL	9
1.1	Terms and Abbreviations.....	9
1.2	Aircraft Maintenance Manual.....	9
1.3	Measuring Principle of the LEAKAGE METER GST 6108.....	10
2	HANDLING	13
2.1	Scope of Delivery.....	13
2.2	Type and Serial Number.....	14
2.3	Transport.....	14
2.4	Storage Conditions.....	15
2.5	Maintenance.....	15
3	SPECIFICATIONS.....	17
4	DESCRIPTION OF THE LEAKAGE METER GST 6108.....	19
4.1	The Transmitter.....	19
4.2	The LEAKAGE Transducer.....	20
5	INSTALLATION OF THE LEAKAGE METER GST 6108.....	23
5.1	Inspection at Reception.....	23
5.2	Mounting the LEAKAGE meter.....	23
5.3	Interface LEAKAGE Transducer ↔ Airplane (Hydraulic System).....	23
6	STARTING UP	25
6.1	General Precautions.....	25
6.2	The Keypad.....	25
6.3	The Display.....	28
6.4	Battery LED.....	29
6.5	Signal LED.....	29
6.6	Status LED.....	29
6.7	Power Supply.....	29
7	PREPARATION OF THE MEASUREMENT.....	31
7.1	Connection of the LEAKAGE Transducer to the Transmitter.....	31
7.2	Mounting of the LEAKAGE Transducer on the Pipe.....	31
8	MEASUREMENT.....	35
8.1	Switching the LEAKAGE meter On.....	35
8.2	Parameter Input.....	35
8.3	Start of Measurement.....	37
8.4	Result of the Measurement.....	40
8.5	Output of the Measured Values to a PC.....	41
8.6	Deleting Measured Values.....	42
8.7	Charging the Battery.....	42
9	SETTINGS.....	44
9.1	Setting the Date and the Time.....	44
9.2	Setting the Contrast.....	45
9.3	Format of the Output.....	45
9.4	Input Mode for the Measuring Point Designation.....	46
9.5	Selection of the Units.....	46
9.6	Instrument Information.....	47
10	TROUBLESHOOTER MODE.....	48
10.1	Switching between the permanent Troubleshooter Mode and the permanent LEAKAGE Mode.....	48
10.2	Switching the Troubleshooter Mode temporarily ON.....	49
10.3	Switching the LEAKAGE Mode temporarily ON.....	50
10.4	Troubleshooting Measurement.....	50

Equipment P/N:
610007AB

Issue: L

Ground Instruction Manual



11	OPERATOR MISUSE.....	53
12	GSE HANDLING IN ACCORDANCE TO THE AMM.....	53
13	TROUBLESHOOTING.....	55
14	SPARE PARTS	57



1 General

1.1 Terms and Abbreviations

AC	Alternating Current
A/C	Aircraft
Acc.	According
AMM	Aircraft Maintenance Manual
Approx.	Approximately
ASCII	American Standard Code for Information Interchange
CRLF	Carriage Return / Line Feed
Cont'd	Continued
Deg.	Degree
e.g.	For example
Fig.	Figure
GIM	Ground Instruction Manual
GSE	Ground Support Equipment
i.e.	That is
Incl.	Including
LCD	Liquid Crystal Display
LED	Light Emitting Diode
Meas.	Measuring
Max.	Maximum
R&D	Research and Development
Read.	Reading
RTS/CTS	Ready To Send / Clear To Send
P/N	Part Number
W x H x D	Width x Height x Depth

1.2 Aircraft Maintenance Manual

A320 family

Maintenance Task:

29-00-00-280-001, Check of the Internal Leakage of the Green Hydraulic System

29-00-00-280-002, Check of the Internal Leakage of the Blue Hydraulic System

29-00-00-280-003, Check of the Internal Leakage of the Yellow Hydraulic System

A330/A340 family

Maintenance Task:

29-19-00-720-801, Check of the Internal Leakage of the Blue and Yellow Hydraulic Systems

29-19-00-720-802, Check of the Internal Leakage of the Green Hydraulic System

A350-900

Maintenance Task:

29-1X-XX-02001-340A-A, Functional Test to Monitor Internal Leak Rate of the Green and Yellow Hydraulic Systems

A380 VDHM

Maintenance Task:

27-54-00-720-803, Functional Test to Monitor Internal Leak Rate of the PCU Hydraulic Motors

1.3 Measuring Principle of the LEAKAGE METER GST 6108

The LEAKAGE meter measures the leak rate in hydraulic systems according to the ultrasonic transit time difference principle. The measurement is non invasive, absolutely no intrusion in the pipe system is needed.

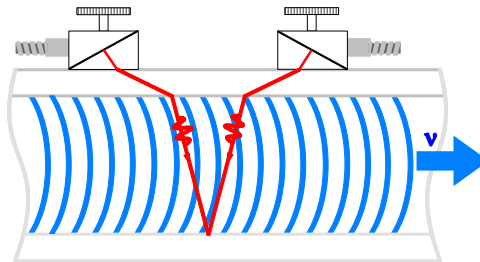

Fig. 1.1: Transit of the ultrasonic signal through the medium

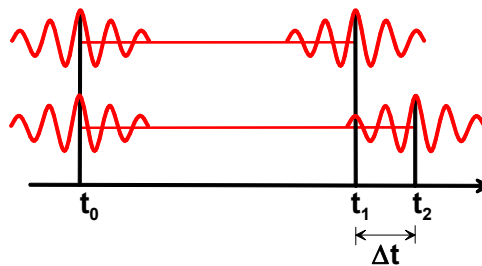

Fig. 1.2: Transit time difference

Ultrasonic signals are sent by the transducer into the pipe, reflected on the inner pipe wall of the opposite side and come back to the transducer. These signals are emitted alternatively in the direction of flow and against it.

Because the medium in which the signals propagate is flowing, the transit time of the sound signals propagating in the direction of flow is shorter than the transit time of the signal propagating against the direction of flow.

The transit time difference Δt is measured and allows the determination of the average flow velocity on the propagation path of the ultrasonic signals. A profile correction is then performed to obtain the average flow velocity on the cross-section of the pipe, which is proportional to the volume flow rate.

Equipment P/N:
610007AB

Issue: L

Ground Instruction Manual



The LEAKAGE meter tests with its special electronics the incoming ultrasonic signals for their usefulness for the measurement and evaluates the plausibility of the measured values. The integrated microprocessors control the complete measuring cycle, eliminating disturbance signals by statistical signal processing techniques.

Equipment P/N:
610007AB

Issue: L

Ground Instruction Manual



2 Handling

2.1 Scope of Delivery

The standard scope of delivery (P/N: 610007AB) comprises:

Item	Description	Quantity
001	Data transfer kit	1
002	Power supply and battery charging unit, 110 V AC – 220 V AC (without power cord)	1
003	Power cord Europe incl. universal adapter	1
004	Coupling compound tube	1
005	User's manual English	1
006	Transmitter GST 6108	1
007	LEAKAGE transducer FS3N7	1
008	Carrying case	1



Fig. 2.1: Carrying case (008) with measuring instrument and accessories

2.2 Type and Serial Number

Type designation and serial number of the LEAKAGE meter are given on the data plate of the rear panel of the transmitter (see Fig. 2.2) and on the side face of the transducers (see Fig. 2.3).



Fig. 2.2: Data plate, transmitter

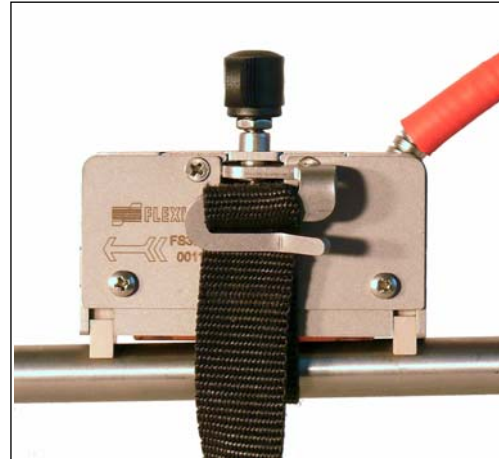

Fig. 2.3: Data plate, transducer

2.3 Transport

- Protect the instrument from shocks during transport. Always stow the instrument and its accessories in the corresponding compartments of the carrying case. Avoid excessive cable bends especially when closing the top cover of the carrying case.
- In order to avoid scratches on the enclosure caused by the instrument handle during transport, tilt the handle to the front of the LEAKAGE meter. To do this, you must first pull the handle to the side to unlock it (see arrow in Fig. 2.4).



Fig. 2.4: Handle with anchoring



2.4 Storage Conditions

- Always store the LEAKAGE meter at an adequate ambient temperature. The temperature should lie between -40 °C and 65 °C (-40 °F and 149 °F). To increase battery life, the temperature should be between 0 °C and 10 °C (32 °F and 50 °F). Storage in a cool place will slow down self-discharge by 10 percent.
- The battery remains in the LEAKAGE meter. Always store the LEAKAGE meter with a fully charged battery.
- The relative humidity of the storage room should lie between 5 % and 95 % without condensation.

2.5 Maintenance

No maintenance work is necessary. If the LEAKAGE meter is installed correctly, in an appropriate location and as recommended, used cautiously and taken care of conscientiously, no troubles should appear.

2.5.1 Cleaning

- Clean the instrument with a soft cloth.
- Do not use detergents.
- Remove traces of acoustic coupling compound from the transducers with a paper tissue.

2.5.2 Calibration

The LEAKAGE meter is a very reliable instrument. It is manufactured under strict quality control, using modern production techniques. The instrument has been calibrated at the factory. FLEXIM recommends to calibrate the LEAKAGE meter once a year or according to local guidelines. The operator is responsible for following this recommendation, at own discretion. The LEAKAGE meter has to be calibrated at the FLEXIM factory.

We recommend calibration if the transducers were used at temperatures outside of the specified temperature range.

Equipment P/N:
610007AB

Issue: L

Ground Instruction Manual





3 Specifications

Specifications are subject to modifications without prior notice.

Measurement

Measuring principle: Ultrasonic time difference correlation principle

Flow velocity: (0.01 ... 25) m/s
[(0.03 ... 82) ft/s]

Resolution: 0.025 cm/s
[0.0008 ft/s]

Repeatability: 0.15% of reading \pm 0.01 m/s
[0.15% of read. \pm 0.03 ft/s]

Accuracy (for fully developed, rotationally symmetrical flow profile)

- Volume flow: \pm 1% ... 3% of read. \pm 0.01 m/s
[\pm 1% ... 3% of read. \pm 0.03 ft/s] depending on application
 \pm 0.5% of reading \pm 0.01 m/s
[\pm 0.5% of read. \pm 0.03 ft/s] with process calibration

-Path velocity: \pm 0.5% of read. \pm 0.01 m/s
[\pm 0.5% of read. \pm 0.03 ft/s]

Accuracy at the defined test points for a LEAKAGE measurement (flow profile not rotationally symmetrical)

- Volume flow: < 7% of read. \pm 0.01 m/s
[< 7% of read. \pm 0.03 ft/s] for T = 10 °C ... 60 °C
[for T = 50 °F ... 140 °F]

Transmitter

Enclosure

-Weight: approx. 3.9 kg ^{*)}
[approx. 8.6 lb]

-Deg. of protection: IP54 acc. to EN60529
[NEMA 3S]

-Material: aluminium, epoxy coated

-Dimensions (W x H x D): (276 x 118 x 317) mm
[(10.87 x 4.64 x 12.48) in] (with handle)

Measuring channels: 1

Power supply: Rechargeable battery (6 V/5 Ah) or external power supply (100-240) V AC

Operating time with battery: >10 h

Charge time for max. capacity: 15 h

Display: 2 x 16 characters, dot matrix, backlit

Operating temperature: -10 °C ... 60 °C
[14 °F ... 140 °F]

Power consumption: < 15 W

Measuring cycle: (100 ... 1000) Hz (1 channel)

Measuring functions

Meas. quantity: Volume flow

Meas. units: l/min or gal/min

Data logger

Loggable values: all measured values

Capacity: Meas. values: >100 000
Meas. series: 99

Communication

Interface: RS232

Data: actual meas. value, logged data, parameter records

Software FluxData (optional)

Function: Downloading meas. data/parameter records, graphical presentation, conversion to other formats (see section 8.5)

Operating systems: Windows TM versions ^{**)} (newer than Windows 98)

LEAKAGE transducer

rated (possible) diameter range: (9 ... 25.4) mm
[(3/8 ... 1) in]

Dimensions (W x H x D): (75 x 41 x 43) mm
[(2.95 x 1.61 x 1.69) in] (without fastening strap)

Material: Enclosure: stainless steel
Contact surface: PEI

Operating temperature: -30°C ... 130°C
[-22°F ... 266°F]

Deg. of protection: IP65 acc. to EN60529
[NEMA 4X]

^{*)} Avoirdupois pound: 1 lb = 0.45359237 kg

^{**)} Windows is a protected trademark of Microsoft Corporation.

Equipment P/N:
610007AB

Issue: L

Ground Instruction Manual



4 Description of the LEAKAGE METER GST 6108

4.1 The Transmitter

4.1.1 Front Panel

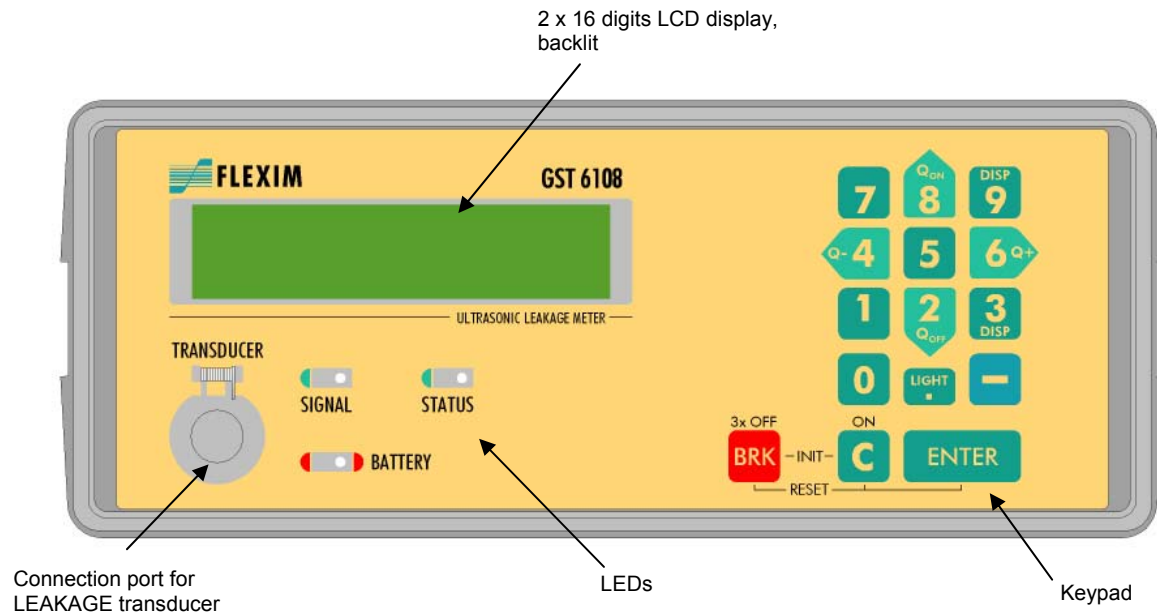

Fig. 4.1: Front panel of the transmitter

4.1.2 Rear Panel

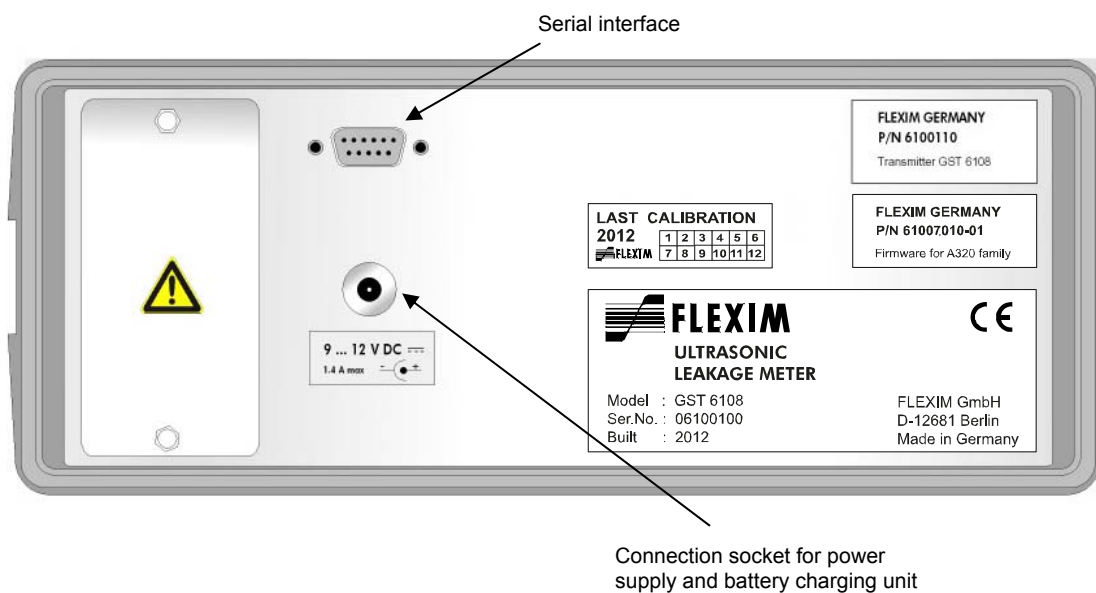

Fig. 4.2: Rear panel of the transmitter

4.1.3 Outer Dimensions of the Transmitter

The transmitter weighs 3.9 kg (8.6 lb). Fig. 4.3 and Fig. 4.4 show the outer dimensions of the transmitter.

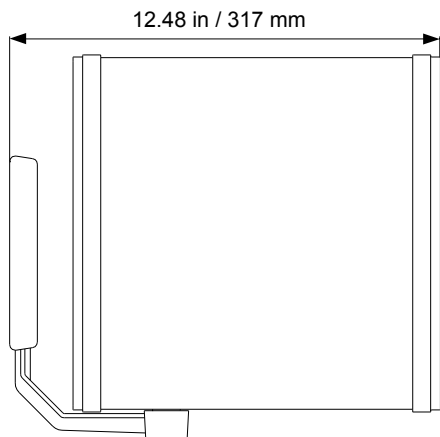

Fig. 4.3: Top view

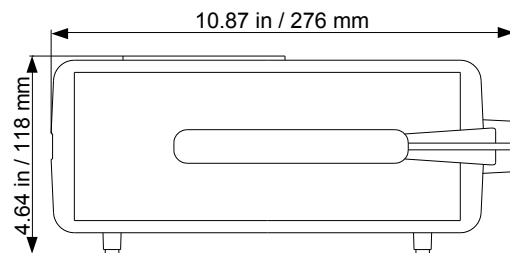

Fig. 4.4: Front view

4.2 The LEAKAGE Transducer

The LEAKAGE transducer (see Fig. 4.5) can be used on pipes of nominal diameter ranging from 9 mm to 25.4 mm (3/8 in to 1 in) and at temperatures between -30 °C and 130 °C (-22 °F and 266 °F).

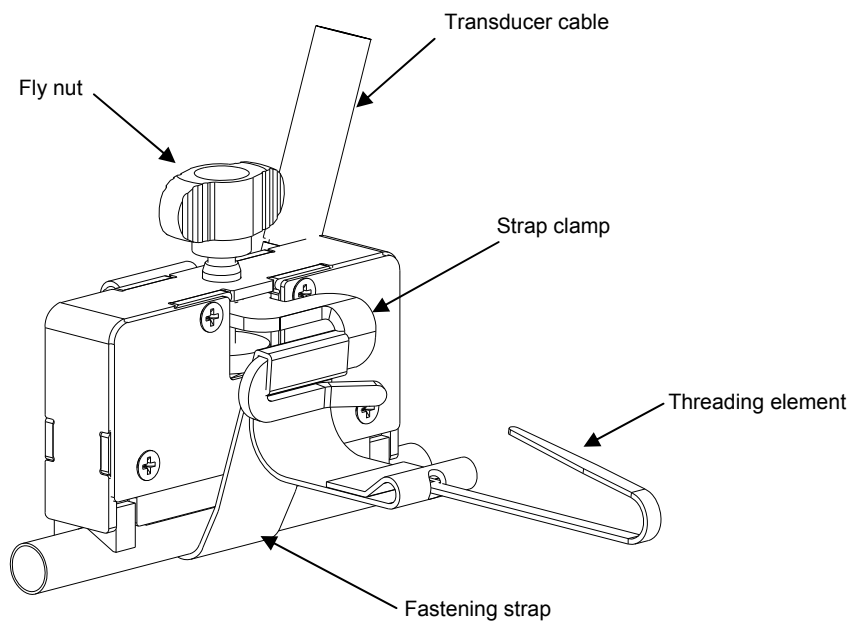

Fig. 4.5: LEAKAGE transducer

Ultrasonic signals are emitted by one measuring head (see Fig. 4.6), reflected on the inner wall of the opposite side and received by the other head.

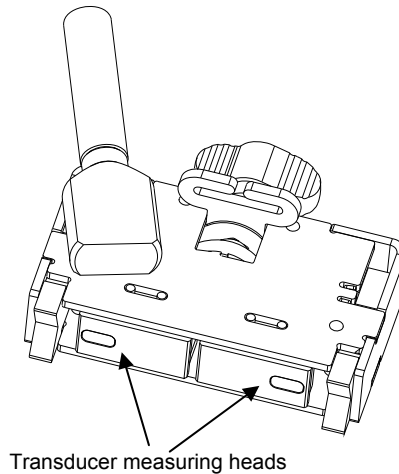

Fig. 4.6: Measuring heads of the LEAKAGE transducer

The transducer is factory calibrated. The calibration data and the transducer parameters are saved in a transducer internal non-volatile memory and are automatically sent to the transmitter upon connection of the transducers to facilitate the operation of the LEAKAGE meter.

4.2.1 Outer Dimensions of the LEAKAGE Transducer

The LEAKAGE transducer weighs 0.5 kg (1.1 lb). The transducer housing and the transducer cable conduit are made of stainless steel. Fig. 4.7 and Fig. 4.8 show the outer dimensions of the LEAKAGE transducer.

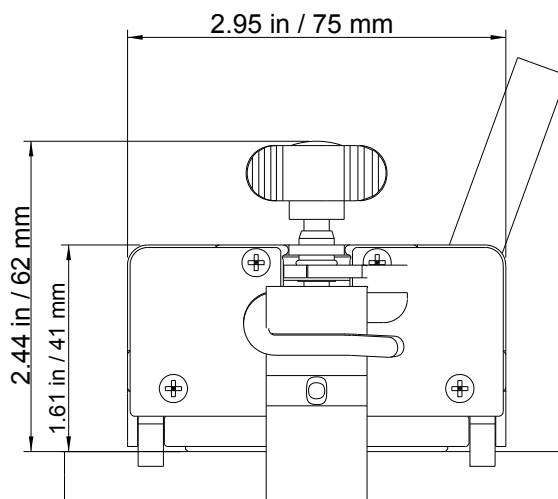

Fig. 4.7: Side view

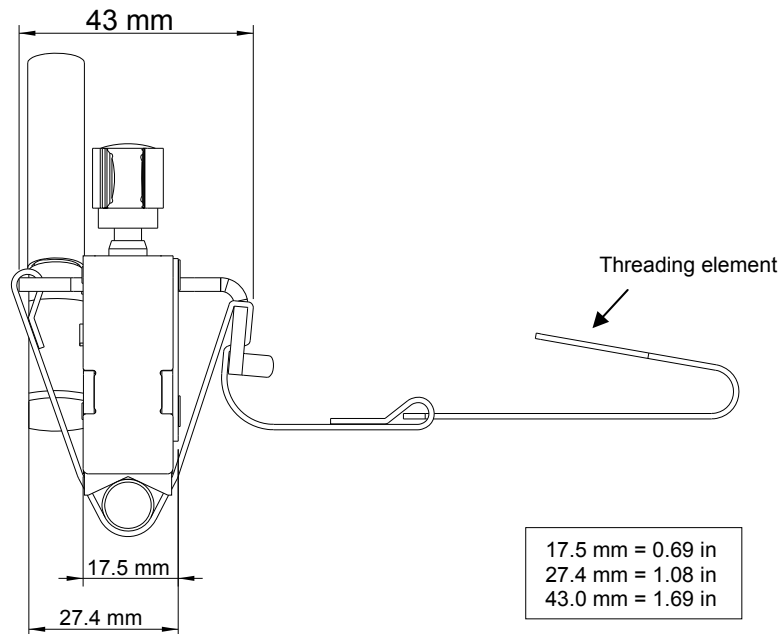

Fig. 4.8: Front view

4.2.2 Temperature Probe

The LEAKAGE transducer is equipped with a temperature probe. The latter is in contact with the surface of the pipe and measures the temperature of the medium (see Fig. 4.9).

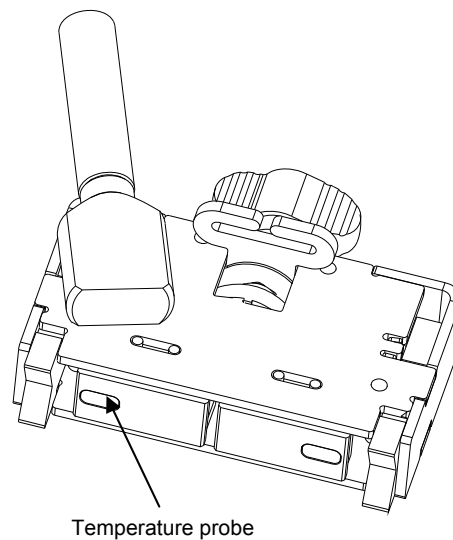

Fig. 4.9: LEAKAGE transducer with temperature probe

5 Installation of the LEAKAGE METER GST 6108

5.1 Inspection at Reception

- This instrument has already been tested thoroughly and has left the works in a flawless state. When the instrument is delivered, please proceed to a visual control of the LEAKAGE meter to make sure that no damage has occurred during transportation.
- Please make sure that the specifications of the instrument and of the transducer that were delivered correspond to the specifications given on the purchase order.
- In order to answer any inquiries, FLEXIM needs the type and the serial number of the instrument as well as the part number of the firmware.

Note: *Type designation and serial number of the LEAKAGE meter are given on the data plate of the rear panel of the transmitter and on the side face of the transducers (see Fig. 2.2 and Fig. 2.3).*

5.2 Mounting the LEAKAGE meter

The LEAKAGE meter is already operational when delivered.

5.3 Interface LEAKAGE Transducer ↔ Airplane (Hydraulic System)

The LEAKAGE transducer is attached to the pipe by means of a fastening strap. The threading element at the end of the strap makes installation easier (see Fig. 5.1).

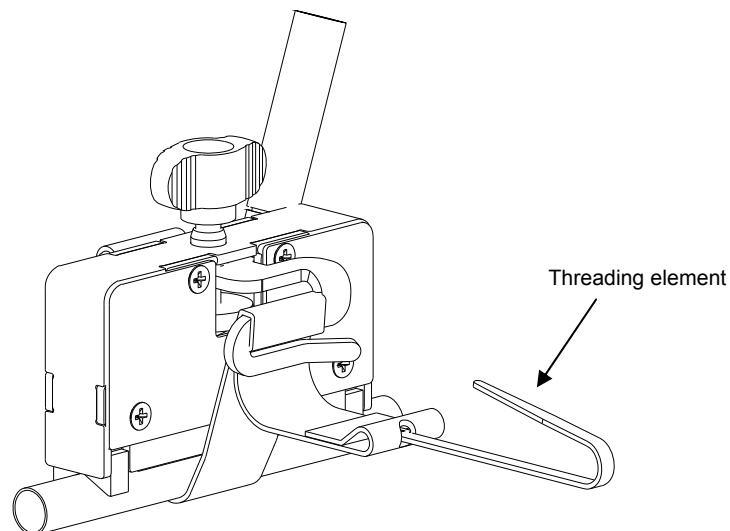

Fig. 5.1: LEAKAGE transducer mounted on a pipe

Equipment P/N:
610007AB

Issue: L

Ground Instruction Manual



6 Starting Up

The LEAKAGE meter must always be operated according to the instructions given in the present User's Manual.

6.1 General Precautions

The LEAKAGE meter is a precision measuring instrument and it must be handled with care. To obtain reliable measurement results and in order not to damage the instrument, it is important that great attention is paid to the instructions given in this User's Manual.

Note: *Always respect the handling precautions and the instructions given in this manual.*

Always respect the following instructions:

- Protect the instrument from excessive shock.
- Do not open the housing without authorization.
- Take the degree of protection into account (see chapter 3).
- Keep the transducers clean.
- Manipulate the transducer cables cautiously. Avoid excessive cable bend.
- Handle the charging unit correctly.
- The power supply and battery charging unit is not moisture-proof. Use it only in dry rooms.
- Make sure to work under correct ambient conditions.
- Use a correct external power supply when not using the battery.

Caution! *Never replace a component of the LEAKAGE meter by a component that was not authorized by FLEXIM.*

6.2 The Keypad

The keypad of the LEAKAGE meter features three function keys and 12 keys for numerical data input.

Several keys have double functions. They can be used for INPUT as well as for SELECTION.

In SELECTION mode, for example, the arrow-shaped numerical keys operate as cursor keys.

In INPUT mode, they can be used for the input of numbers and characters.

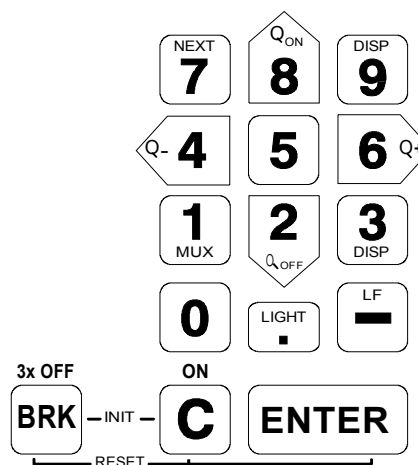

Fig. 6.1: Keypad



Table 6.1: General functions

	<p>Press this key to switch the LEAKAGE meter ON.</p>
	<p>Switches the background lighting ON/OFF.</p>
	<p>RESET: Press these keys simultaneously to recover from an error. This has the same effect as restarting the unit. The stored data will not be affected.</p>
	<p>INIT (cold start): To initialize the LEAKAGE meter, press these keys simultaneously while switching the LEAKAGE meter ON and hold them down until the main menu appears. Most parameters and settings are reset to the factory default values. The memory will not be cleared.</p>
	<p>Press 3 times BRK to switch the LEAKAGE meter OFF.</p>
	<p>Interrupts the measurement and calls the main menu.</p>

Caution! *Be careful not to interrupt an ongoing measurement by inadvertently pressing BRK*

Table 6.2: Menu selections

	<p>Press BRK to call the main menu.</p>
	<p>Selecting the menu entry at the left or at the right of the currently highlighted one.</p>
	<p>Scrolling upwards or downwards through the menus.</p>
	<p>Confirmation of the selected entry. The corresponding program branch appears.</p>

Table 6.3: Input of numerical values

















 ... 	Input of the numerical value shown on the key
	Sign for the input of negative data
	Decimal point
	Deletion of data. After the deletion of data, the previous value will be displayed.
	Confirmation of input.

Table 6.4: Input of text

 	Selection of the position of the character to be input.
	Changes the currently selected character to an 'A'.
	Changes the currently selected character to a 'Z'.
	Changes between small and capital letters.
 	Moving to the next/previous ASCII character.
	Deleting the character currently shown and inserts a blank space.
 	To automatically scroll upwards/downwards through the selected restricted ASCII character set. The character changes every second. The scrolling can be interrupted by pressing any other key.
	Finishes editing.

6.3 The Display

6.3.1 The Main Menu



```
>MEASURING<  sf
Leakage measure
```

After switching on and initialization, the main menu appears on the first line of the display.

The main menu has two entries:

- MEAS (Measuring) and
- SF (Special Functions),

corresponding to the two different program branches.

The actually selected program branch is displayed in capital letters between arrows. Use keys  **4** and  **6** to select a program branch.

6.3.2 The Program Branches

The program branch MEASURING leads you through the different steps of the measuring process.

The program branch SPECIAL FUNCTIONS contains all functions that are not directly related with the basic measurement.



```
Special Funct.  ⬆
SETUP:Date/Time
```

If a vertical arrow (⬆) is displayed beside a menu option, this menu option contains a scroll list. This list is displayed on the second line.

Use the arrow keys  **8** and  **2**, to scroll through the list, then confirm your selection by pressing ENTER.

```
TIME          11:11
>OK<         new
```

The LEAKAGE meter sometimes requests a selection on the second line. The actually selected option is displayed in capital letters and between arrows.

Use the arrow keys  **4** and  **6**, then confirm your selection by pressing ENTER.

Note: You can return to the main menu at any time by pressing key BRK.

Note: In this manual, all program entries and keys will appear in capital letters. Program entries are in typewriter characters (PARAMETER). Submenus are separated from the main menu entry by a backslash.



6.4 Battery LED

Table 6.5: Function of the "Battery" LED

LED off:	The LEAKAGE meter works under normal operating conditions (battery or external power supply).
LED on:	Battery is being charged.
LED flashes (long intervals):	Battery voltage is insufficient. Measurements are impossible. Battery must be charged or replaced. Note: The battery may only be replaced by FLEXIM. For this purpose send the LEAKAGE meter to FLEXIM.
LED flashes (short intervals):	Error during battery charging, e.g. no external voltage present.

6.5 Signal LED

Table 6.6: Function of the "Signal" LED

LED off:	The LEAKAGE meter works offline.
LED on (green):	The signal received by the channel is sufficient for measurements.
LED on (red):	The signal received by the channel is insufficient for measurements.

6.6 Status LED

Table 6.7: Function of the "Status" LED

LED off:	The measurement is taking place.
LED on (green):	The measured value lies within the specified range.
LED on (red):	The measured value lies outside the specified range.

6.7 Power Supply

The chargeable NiMH batteries guarantee an operating time of at least 10 hours. The instrument can also be operated from an external power supply of (100 to 240) V AC using the provided power supply and battery charging unit.

Caution! *The power supply and battery charging unit is not moisture-proof. Use it only in dry rooms.*

Note: *The battery may only be replaced by FLEXIM. For this purpose send the LEAKAGE meter to FLEXIM.*

Equipment P/N:
610007AB

Issue: L

Ground Instruction Manual



Note: *The battery can be recharged as described in section 8.7.*

To avoid the so-called memory effect (battery has to be charged in ever shorter intervals and capacity decreases over time), always discharge the battery completely before recharging it.

Caution! *Before recharging, discharge the battery as far as possible in order to avoid overcharging. The LEAKAGE meter signalizes that the battery is discharged as follows:*

LOW BATTERY !

If the LOW BATTERY ! message appears on the display, there is one hour of battery life left.

7 Preparation of the Measurement

7.1 Connection of the LEAKAGE Transducer to the Transmitter

Connect the LEAKAGE transducer with the transmitter as follows:

- Pull up the socket cover of transducer socket.
- Insert the connector of the transducer cable in the socket.



Fig. 7.1: Connection of the transducer

Note: *The red point on the connector should face the red marking on the socket.*

7.2 Mounting of the LEAKAGE Transducer on the Pipe

Mount the transducer on the pipe as follows:

- Apply a thin film of acoustic coupling compound on the contact surfaces of the transducer heads (see Fig. 7.2).

Note: *You will obtain the correct film thickness by stroking over the contact surface with a finger.*

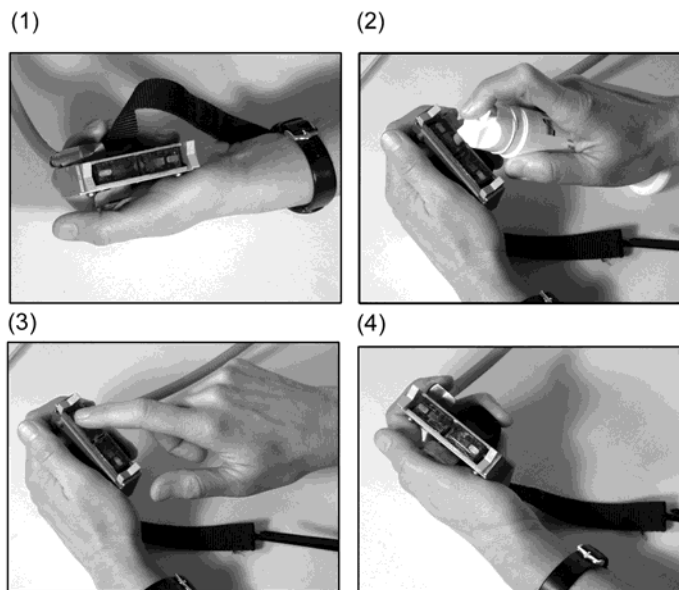

Fig. 7.2: Applying the coupling compound

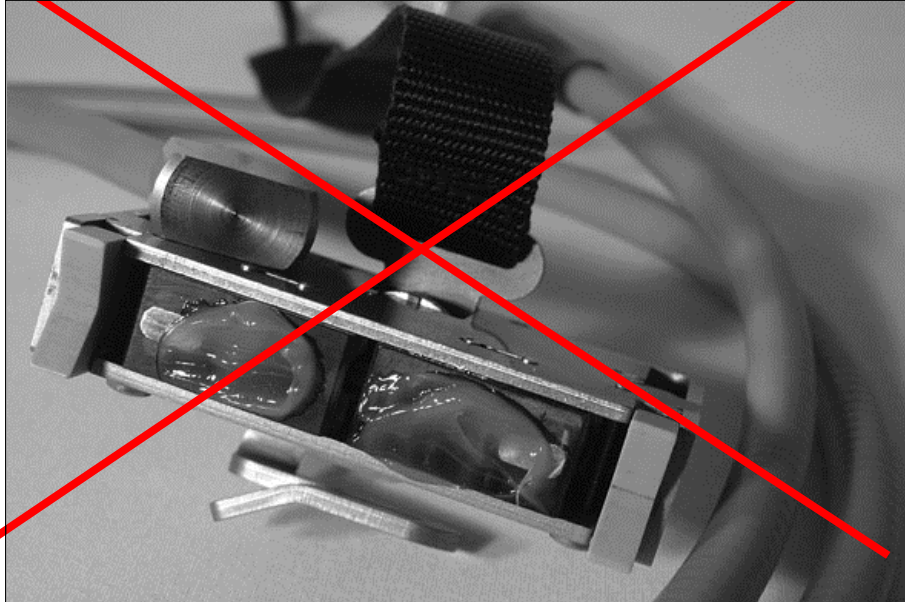

Fig. 7.3: Caution! Do not apply too much coupling compound.

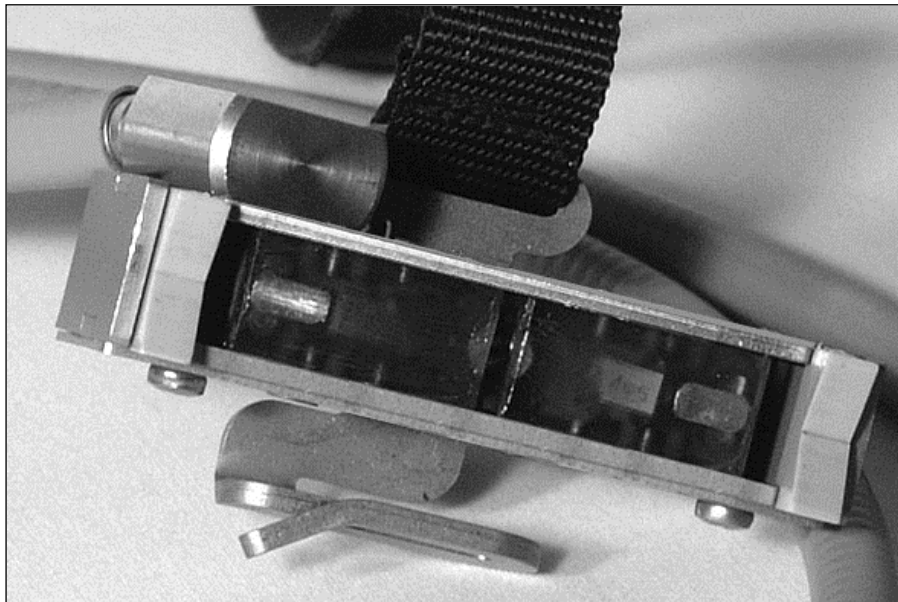

Fig. 7.4: Caution! Apply a thin film of coupling compound over the complete surface of the transducer measuring heads.

- Place the transducer on the pipe and press the fly nut firmly (see Fig. 7.5). Put the fastening strap around the pipe. Use the threading element at the end of the strap as threading aid.

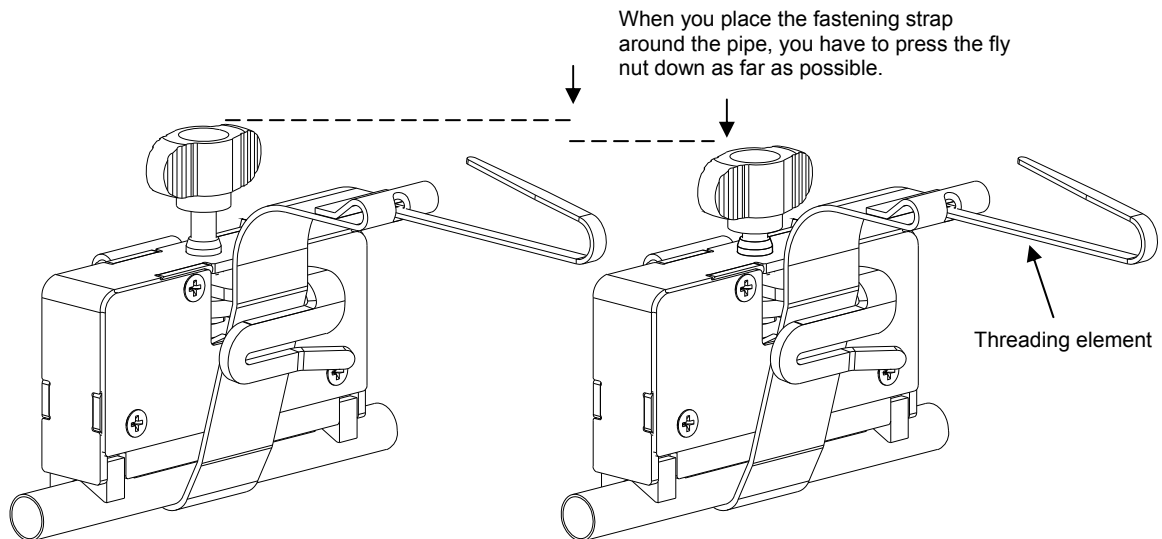

Fig. 7.5: Attaching the fastening strap to the pipe

- First guide the fastening strap through the upper slot of the strap clamp, and then through the lower one (see Fig. 7.6). Make sure that the strap is tensioned properly and that the fly nut has been pressed in up to the stop.

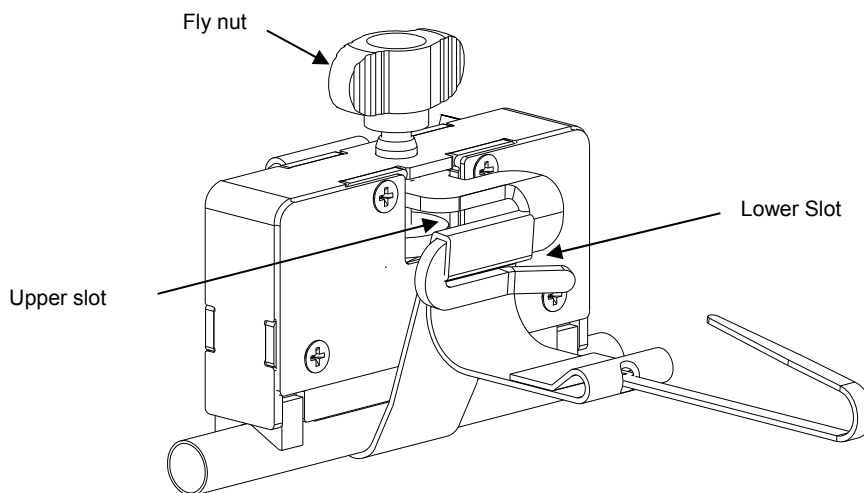

Fig. 7.6: Threading the fastening strap

- Fasten the transducer and the fastening strap by tightening the fly nut.

Note: A stop limits the deflection of the spring. The fly nut can not be turned past this stop.

Equipment P/N:
610007AB

Issue: L

Ground Instruction Manual





8 Measurement

Caution! Always wait until thermal equilibrium between the outer surface of the pipe wall and the temperature probe has been reached before you start the measurement.

8.1 Switching the LEAKAGE meter On

Press key  to switch the transmitter on.

```
FLEXIM
GST 6108-06100106
```

After the LEAKAGE meter has been switched on, the serial number of the instrument is displayed for a second or two.

```
FREE: 99 Sets
      30000 Values
```

The memory still available for data storage is displayed. Here: 99 data sets (SETS) or 30 000 measured values (VALUES) can still be stored.

After that, the main menu appears.

```
>MEASURING< sf
Leakage measure
```

The main menu has two entries:

- MEAS (Measuring) and
- SF (Special Functions).

Note: If the display *Trouble shooter* appears, the *Troubleshooter mode* is activated. To deactivate this mode, see chapter 10.

Note: The display *Leakage measure* appears only if the LEAKAGE transducer is connected with the transmitter.

If the transducer is not connected, the following display appears after the transmitter has been switched on:

```
>MEASURING< sf
CONNECT SENSOR !
```

Connect the transducer to the transmitter. The measurement can only be started when the transducer is connected and the transmitter has detected it.

```
*LEAKAGE SENSOR*
*   DETECTED   *
```

The transducer has now been detected. The program branch MEASURING can now be selected.

8.2 Parameter Input

```
>MEASURING< sf
Leakage measure
```

In the main menu, select the program branch MEASURING and press ENTER.

Equipment P/N:
610007AB

Issue: L

Ground Instruction Manual



The LEAKAGE meter then asks you to enter the serial number of the airplane.

```
Aircraft -No.:  
12345678
```

Here you can enter the serial number of the airplane. The serial number is saved with the measured values, and appears in the documentation. The number has no influence on the measurement.

Enter the number and confirm your entry with ENTER. The input can take place in numerical mode or in text mode.

Note: To change the input mode, select the option *SETUP:A/C-NO.* in the program branch *SPECIAL FUNCTIONS* (see section 9.4).

```
INPUT LOCATION  
CODE: -----
```

The LEAKAGE meter asks for the checkpoint code.

Refer to the Aircraft Maintenance Manual (AMM).

A320 family

Maintenance Task:

29-00-00-280-001, Check of the Internal Leakage of the Green Hydraulic System

29-00-00-280-002, Check of the Internal Leakage of the Blue Hydraulic System

29-00-00-280-003, Check of the Internal Leakage of the Yellow Hydraulic System

A330/A340 family

Maintenance Task:

29-19-00-720-801, Check of the Internal Leakage of the Blue and Yellow Hydraulic Systems

29-19-00-720-802, Check of the Internal Leakage of the Green Hydraulic System

A350-900

Maintenance Task:

29-1X-XX-02001-340A-A, Functional Test to Monitor Internal Leak Rate of the Green and Yellow Hydraulic Systems

A380 VDHM

Maintenance Task:

27-54-00-720-803, Functional Test to Monitor Internal Leak Rate of the PCU Hydraulic Motors

If the entered code is wrong the following error message appears:

```
INVALID CODE  
Please try again
```

Invalid code!

Enter the correct checkpoint code.

When the entered code is correct, the name of the checkpoint is displayed.

```
LOCATION
Gr comp  -10
```

In the opposite display, the name of the checkpoint is: Gr comp -10. Press any key to go on.

Before starting the measurement, the LEAKAGE meter checks if there is still place for the measured values in the data logger.

```
DATA MEMORY
OVERFLOW
```

If the data logger is full, delete the logged values in the program branch SPECIAL FUNCTION / DELETE MEAS.VAL. (see section 8.6).

The LEAKAGE meter now displays information about the quality of the coupling between the transducer and the pipe (C = coupling quality) and about the signal amplitude (S).

```
C: ■■■■■■
S: ■■■■■■■■■■
```

Press key  to scroll on the upper line between the display of the bar graph of the signal amplitude (S), the bar graph of the quality of the signal (C) and the display of the transit time (time) in microseconds.

If the signal received is sufficient for measurement, the SIGNAL LED shows green. Confirm with ENTER to start the measurement.

If the signal received is NOT sufficient for measurement, the SIGNAL LED shows red. In this case:

- make sure that you have applied enough coupling compound on the transducer and
- that there is no dirt between the transducer and the pipe.

If the SIGNAL LED still shows red after that, refer to chapter 13.

8.3 Start of Measurement

```
PLEASE WAIT ...!
■■■■■■■■■■
```

The measurement takes place. The bar graph on the second line of the display shows the progress of the measurement. The measurement lasts approximately 1 min. During this time, a value is measured and saved every second.

```
*** PASSED ***
FLOW= 2.55 l/m
```

The result of the measurement is displayed on the first line: PASSED means that the measurement was successful (see section 8.4). The average measured value is displayed on the second line of the display.

If the temperature sensor has not yet reached the fluid temperature, the following message is displayed:

```
PLEASE WAIT ...!
Temp.adaption...
```

The start of measurement will be delayed until the temperature measurement values are sufficiently constant.

As the measurement takes place, you can let the LEAKAGE meter display special measured values:

a) By scrolling on the second line of the display with key  ^{DISP}, following values will be displayed:

16.04 l/min

- the actual flow,

* 163.40 cm/s

- the actual flow velocity and

c = 1304,4 m/s

- the actual sound speed.

b) By scrolling on the first line of the display with key  ^{DISP} following values will be displayed:

dTf= 0.1 °C/s

- the variation of the fluid temperature per time unit,

C= ■■■■■■■■

- the bar graph of the quality of the coupling between the transducer and the pipe C (coupling quality),

Volume flow

- the actual measurement quantity (here the flow),

Tf= 43.5 C

- the temperature of the fluid,

FULL=24.11/14:15

- the date and the time left until the data logger is full,

S8 Q5 c ? RT F ?

- the status line, which gives you information about the quality and the precision of the actual measurement (see Table 8.1).



Table 8.1: Signification of the elements of the status line

	Values	Signification
S		Signal amplitude:
	0 ... 9	< 5% ... >= 90%
Q		Signal quality:
	0 ... 9	< 5% ... >= 90%
c		Sound speed: Comparison of the measured and expected sound speed in the fluid. The expected sound velocity is calculated by the instrument based on the fluid data.
	↑ √ ↓ ?	greater than 20% of the expected value ok, corresponds to the expected value smaller than 20% of the expected value unknown, can not be measured
R		Flow profile: Information about the flow profile basing on the value of the Reynold's number.
	T ↑↓ L ?	fully turbulent profile the flow is in the transition range between laminar and turbulent flow fully laminar flow unknown, can not be calculated
F		Flow velocity: Comparison of the measured flow velocity with the flow limits of the system.
	↑ ↓ 0 √ ?	the flow velocity is higher than the actual limit the flow velocity is lower than the actual cut-off flow (even if it is not subsequently set to zero) the flow velocity is in the offset range of the measuring method ok, flow velocity is not in a critical range unknown, can not be measured

Table 8.2: Example

Status line:	S8 Q5 c√ RT F↓
S8	Signal amplitude is 80%
Q5	Signal quality is 50%
c√	The measured sound velocity is in the expected range.
RT	Fully turbulent flow
F↓	Flow velocity smaller than the actual cut-off flow

8.4 Result of the Measurement

8.4.1 A320 family, A330/A340 family, A350-900

When the measurement is finished, the flow is displayed on the second line of the display.

```
*** PASSED ***  
FLOW= 2.55 l/m
```

The result of the measurement is displayed on the first line. **PASSED** means that the measurement was successful and that the measured value lies within the specified range. The valid range for measured values is specified in the Aircraft Maintenance Manual (AMM).

You can now press ENTER to restart the measurement.

Note: *In the program branch **SPECIAL FUNCTIONS/SETUP:ENG.UNITS**, you can select the flow unit (l/min or gal/min). See section 9.5.*

If the measured value does not lie within the specified range, one of the following error messages is displayed:

```
FAIL: Flow > Max  
FLOW= 12.04 l/m
```

The flow is higher than the specified upper limit.

```
FAIL: Temp > Max  
FLOW = 2.3 l/m
```

The temperature is higher than the specified upper limit.

```
FAIL: Temp < Min  
FLOW = 2.3 l/m
```

The temperature is lower than the specified lower limit.

```
FAIL: Disturbed  
FLOW= 2.21 l/m
```

The scattering of the measured values is too high.

Control the fastening of the transducer on the pipe and the quality (C) of the measurement signal.

```
FAIL: undefined  
FLOW= undef l/m
```

The measurement was interrupted because of an insufficient number of measured values.

If the measured value is not within the specified range, consult the AMM.

The Troubleshooter mode can help you to identify the cause of the problem. To start the Troubleshooter mode see chapter 10.

To display the lower and upper limit of the flow for the selected checkpoint, use key **3** to scroll the second line of the display.

```
*** PASSED ***  
Max= 9.00 l/m
```

Press the key once to have the upper limit of the flow (MAX=) displayed.



```
*** PASSED ***  
Min= 1.50 l/m
```

Press the key again to have the lower limit of the flow (MIN=) displayed.

When the measurement is finished, press BRK to return to the main menu. You can start a new measurement as described in sections 8.2, 8.3 and 8.4.

8.4.2 A380 VDHM

When the measurement is finished, the flow is displayed on the second line of the display.

```
*** FINISHED ***  
FLOW = 0.90 l/m
```

The result of the measurement is displayed on the first line. FINISHED means that the measured value is not evaluated. Only the temperature is checked.

You can now press ENTER to restart the measurement.

Note: *In the program branch SPECIAL FUNCTIONS/SETUP:ENG.UNITS, you can select the flow unit (l/min or gal/min). See section 9.5.*

If the measured value does not lie within the specified range, one of the following error messages is displayed:

```
FAIL: Temp > Max  
FLOW = 2.3 l/m
```

The temperature is higher than the specified upper limit.

```
FAIL: Temp < Min  
FLOW = 2.3 l/m
```

The temperature is lower than the specified lower limit.

If the measured value is not within the specified range, consult the AMM.

The Troubleshooter mode can help you to identify the cause of the problem. To start the Troubleshooter mode see chapter 10.

When the measurement is finished, press BRK to return to the main menu. You can start a new measurement as described in sections 8.2, 8.3 and 8.4.

8.5 Output of the Measured Values to a PC

The measured values stored in the data logger can be transmitted as ASCII-file to a terminal program (e.g. HyperTerminal under Windows).

The transmission parameters are as follows:

- RS232 with 9600 bits per second, 8 data bits, even parity, 2 stop bits,
- hardware handshaking (RTS/CTS).
- The LEAKAGE meter sends CRLF-terminated ASCII.
- Maximal line length: 255 characters.

Note: *The PC Software FluxData can be used for greater user-friendliness.*



Select the program branch `SPECIAL FUNCTIONS`. Confirm by pressing `ENTER`.

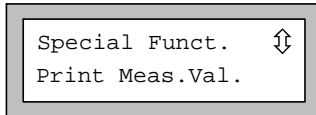

Scroll with key  **8** through the menu until the option `PRINT MEAS.VAL.` is displayed. Confirm by pressing `ENTER`.

Note: *The format of the serial output can be set in the program branch `SPECIAL FUNCTIONS \ SETUP:SERIAL` (see section 9.3).*

Connect the `LEAKAGE` meter to a PC equipped with a serial interface. Press `ENTER` to start the output of the stored measured values.

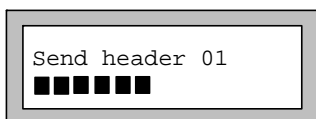

The display indicates that the measured values are being transmitted. The measurement series 01 is transmitted first.

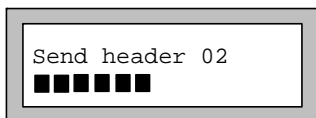

The series 02 is transmitted afterward, and so on until all measurement series are transmitted. The main menu is then displayed.

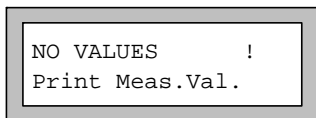

If no measured values are logged, the opposite error message is displayed.

8.6 Deleting Measured Values

Select the program branch `SPECIAL FUNCTIONS`. Confirm by pressing `ENTER`.

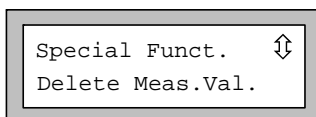

Scroll with key  **8** through the menu until the option `DELETE MEAS.VAL.` is displayed. Confirm by pressing `ENTER`.

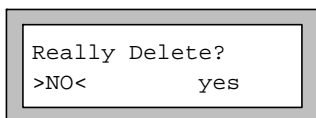

To avoid accidental deletion of data, the `LEAKAGE` meter asks for confirmation to make sure you really want to delete the stored measured values. Confirm your selection by pressing `ENTER`.

8.7 Charging the Battery

Select the program branch `SPECIAL FUNCTIONS`. Confirm by pressing `ENTER`.

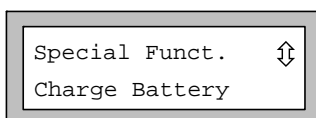

Scroll with key  **8** through the menu until the option `CHARGE BATTERY` is displayed. Confirm by pressing `ENTER`.



```
NO EXTERN. POWER  
Charg.Impossible
```

The opposite error message appears if you have activated the battery charging process although the LEAKAGE meter is not connected to an external power supply. Confirm by pressing ENTER.

```
Charge Time Batt  
15.0 h
```

Enter the desired charging time for the battery (maximum: 15 h). Confirm by pressing ENTER.

Note: *The time necessary for full recharging of the battery is 15h. The charging current is 400 mA.*

```
Battery Charging  
(15:00) 12:30 *
```

The selected charging time is displayed in parenthesis on the left of the display. The remaining charging time is displayed on the right.

A * is displayed every second to signal that the charging process is running. Press ENTER.

```
 BATTERY
```

During battery charging, the battery LED is lighted.

```
Stop Charging  
no >YES<
```

The charging process continues in background mode and the opposite display appears.

Select YES and confirm by pressing ENTER to stop the battery charging process. The main menu will appear.

Select NO and ENTER to continue the battery charging process in the background. The main menu will appear.

```
**Batt. Charg.**  
** Done **
```

A message will appear when the battery charging process is completed, provided it did not run in background mode.

If the external power supply is disconnected during the charging process, the following error message will appear:

```
NO EXTERN.POWER  
(15:00) 11:00 -
```

The LEAKAGE meter stops the battery charging process. The remaining charging time will be saved (for example 11 hours).

When the external power supply is reconnected, the charging will continue for the remaining time.

```
 BATTERY
```

If there is a battery charging error, i.e. there is no external power supply, the battery LED flashes (0.5 Hz).

9 Settings

9.1 Setting the Date and the Time

Select the program branch `SPECIAL FUNCTIONS`. Confirm by pressing `ENTER`.

```
Special Funct.  ⬆
SETUP:Date/Time
```

Scroll with key  through the menu until the option `SETUP:DATE/TIME` is displayed. Confirm by pressing `ENTER`.

The `LEAKAGE` meter features a battery buffered clock. During measurement, the data are automatically stamped with date and time.

9.1.1 Setting the Time



```
SYSTEM settings
Set Clock
```



Scroll with key  through the menu until the option `SET CLOCK` is displayed. Confirm by pressing `ENTER`.

```
TIME      11:00
ok        >NEW<
```

The actual time is displayed.
Select `OK` to confirm or `NEW` to set the time.
Confirm by pressing `ENTER`.

```
TIME      11:00
Set Time  !
```

Use keys  and  to select the digit to be edited.

Use keys  and  to edit the selected digit. Confirm your setting by pressing `ENTER`.

```
TIME      11:11
>OK<     new
```

The next display shows the newly set time.
Select `OK` to confirm or `NEW` to set the time again. Confirm by pressing `ENTER`.



9.1.2 Setting the Date

After the time has been set, the `DATE` display appears.

```
DATE  25.01.2002
ok    >NEW<
```

Select `OK` to confirm or `NEW` to set the date.
Confirm by pressing `ENTER`.

```
DATE  25.01.2002
Set Date  !
```

Use keys  and  to select the digit to be edited.

Use keys  and  to edit the selected digit.

Confirm your setting by pressing `ENTER`.

```
DATE 26.01.2002
>OK<          new
```

The next display shows the newly set date and asks for confirmation. Select **OK** to confirm or **NEW** to set the date again. Confirm by pressing **ENTER**.





9.2 Setting the Contrast

Select the program branch **SPECIAL FUNCTIONS**. Confirm by pressing **ENTER**.

```
Special Funct.  ⬆
SETUP:Contrast
```

Scroll with key  through the menu until the option **SETUP:CONTRAST** is displayed. Confirm by pressing **ENTER**.

Set the contrast of the display using the following keys:

-  increases contrast
-  decreases contrast
-  = minimum contrast
-  = medium contrast
-  = maximum contrast

```
SETUP DISPLAY
<  CONTRAST  >
```

9.3 Format of the Output

Select the program branch **SPECIAL FUNCTIONS**. Confirm by pressing **ENTER**.

```
Special Funct.  ⬆
SETUP:Serial
```

Scroll with key  through the menu until the option **SETUP:SERIAL** is displayed. Confirm by pressing **ENTER**.

```
SER:kill spaces
off          >ON<
```

Select **ON** if you don't want to have the space characters transmitted. In this way, the file size and thus the transmission time can be considerably reduced.

```
SER:decimalpoint
'.'          >','<
```

Select the decimal separation to be used for floating point variables: point or comma.

```
SER:col-separat.
';'          >'TAB'<
```

Select the characters to be used for separating columns: semicolon or tabulator. This setting depends on the requirements of the PC program.

9.4 Input Mode for the Measuring Point Designation

Select the program branch `SPECIAL FUNCTIONS`. Confirm by pressing `ENTER`. In numerical mode, only numbers, point and dash can be input.

```
Special Funct.  ⬆⬇
SETUP:A/C-No.
```

Scroll with key  through the menu until the option `SETUP:A/C-NO.` is displayed.

Confirm by pressing `ENTER`.

```
Input A/C-No.
>(1234)<  (↑↓←→)
```

Select `(1234)`, if you wish to identify the measuring points using only numbers, point and dash.

Select `(↑↓←→)` if you wish to enter the measuring point designations using the ASCII-editor. Confirm by pressing `ENTER`.

9.5 Selection of the Units

Select the program branch `SPECIAL FUNCTIONS`. Confirm by pressing `ENTER`.

```
Special Funct.  ⬆⬇
SETUP:Eng.units
```

Scroll with key  through the menu until the option `SETUP:ENG.UNITS` is displayed. Confirm by pressing `ENTER`.

```
Volume in  ⬆⬇
l/min
```

Select with key  the units of the volume flow:

`l/min` or `gal/min`.

Confirm by pressing `ENTER`.

```
Velocity in  ⬆⬇
cm/s
```

Select with key  the units of the flow velocity:

`cm/s` or `ft/s`.

Confirm by pressing `ENTER`.

```
Temperature
>[°C]<  [F]
```

Select with key  the units of the temperature: `°C` or `°F`. Confirm by pressing `ENTER`.

9.6 Instrument Information

Select the program branch `SPECIAL FUNCTIONS`. Confirm by pressing `ENTER`.

```
Special Funct.  ⬆⬇
Instrum.Inform.
```

Scroll with key  through the menu until the option `INSTRUM.INFORM` is displayed. Confirm by pressing `ENTER`.

```
FREE:  99 Sets
       30000 Values
```

The memory still available for data storage is displayed on the first line. Here: 99 measuring series or 30 000 measured values can still be stored. Confirm the displayed information by pressing `ENTER`.

```
GST6108-06100100
PartNo:  6100110
```

The serial number of the instrument is displayed on the first line. The part number of the instrument is displayed on the second line. Confirm by pressing `ENTER`.

```
Firmware PN6100  ⬆⬇
A320:    7010-01
```

The part number of the firmware for the supported aircraft is displayed.

Scroll with key  through the list of supported aircraft models. Confirm by pressing `ENTER`.



10 Troubleshooter Mode

The LEAKAGE meter can be operated in two modes: in the LEAKAGE mode and in the Troubleshooter mode. The default mode is the LEAKAGE mode. If it is activated, the leak rate can be measured.

The Troubleshooter mode is an additional mode. If it is activated, it is possible to use the LEAKAGE meter as a flowmeter. Thus the volume flow can be measured on each measuring point in the hydraulic system, also on measuring points that are not calibrated.

Note: *The estimated error can be up to 20% when the volume flow is measured with the Troubleshooter mode.*

By measuring the volume flow on different measuring points, conclusions can be drawn, how the hydraulic system works. By this means cause of problems can be detected. A rough indication of a problem is, when there is a high difference between measured values and normal operating data.

Note: *If a problem is indicated, refer to the AMM for further steps.*

Note the following points, when the Troubleshooter mode is used:

- Only the volume flow can be measured in the Troubleshooter mode.
- The leak rate can not be measured.
- The estimated error can be up to 20%.
- The measured results can not be stored and not be evaluated.
- Only the pipe type has to be selected.

The Troubleshooter mode can be activated permanently or temporarily. That also applies to the LEAKAGE mode.

If the Troubleshooter mode is permanent, the LEAKAGE mode can be activated temporarily. If the LEAKAGE mode is permanent, the Troubleshooter mode can be activated temporarily.

To switch between the Troubleshooter mode and the LEAKAGE mode, a HotCode has to be entered.

10.1 Switching between the permanent Troubleshooter Mode and the permanent LEAKAGE Mode

To activate or deactivate the Troubleshooter mode permanently, enter HotCode 066747 immediately after switching the transmitter ON. The following display appears:

```
Trouble shooter.  
off >ON<
```

Select ON to activate the Troubleshooter mode permanently or OFF to deactivate it and activate the LEAKAGE mode. Confirm by pressing ENTER.

If you select ON the following display appears:

```
Trouble shooter.  
Up to 20% error!
```

The display indicates that the estimated error could be up to 20%. Confirm by pressing ENTER.

```
>MEASURING<  sf
Trouble shooter
```

The main menu of the Troubleshooter mode is displayed. The Troubleshooting measurement can now be started (see section 10.4).

Note: This display appears only if the LEAKAGE transducer is connected with the transmitter.

If the Troubleshooter mode is activated permanently, it will not be deactivated when the transmitter is switched OFF.

If you select OFF the following display appears.

```
FREE:  99 Sets
       30000 Values
```

The memory still available for data storage is displayed. Here: 99 data sets (SETS) or 30 000 measured values (VALUES) can still be stored.

```
>MEASURING<  sf
Leakage measure
```

The main menu of the LEAKAGE mode is displayed (see chapter 8). The LEAKAGE mode is activated.

Note: This display appears only if the LEAKAGE transducer is connected with the transmitter.

Note: *If the following message appears after input of the HotCode to change into LEAKAGE mode, the LEAKAGE meter does not support any aircrafts:*

```
*      ONLY      *
Trouble shooter!
```

Only the volume flow can be measured in the Troubleshooter mode. No measurement of the leak rate is possible. If you want to use the LEAKAGE mode to measure the leak rate in hydraulic systems, consult FLEXIM.

If the LEAKAGE mode is activated permanently, it will not be deactivated when the transmitter is switched OFF.

10.2 Switching the Troubleshooter Mode temporarily ON

If the LEAKAGE mode is activated permanently, the Troubleshooter mode can be activated temporarily by entering HotCode 065380 immediately after switching the transmitter ON. The following display appears:

```
Trouble shooter.
Up to 20% error!
```

The display indicates that the estimated error could be up to 20%. Confirm by pressing ENTER.

```
>MEASURING<  sf
Trouble shooter
```

The main menu of the Troubleshooter mode is displayed. The Troubleshooting measurement can be started (see section 10.4).

Note: This display appears only if the LEAKAGE transducer is connected with the transmitter.

If the Troubleshooter mode is activated temporarily, it will not be activated when the transmitter is switched OFF and ON again.



10.3 Switching the LEAKAGE Mode temporarily ON

If the Troubleshooter mode is activated permanently, the LEAKAGE mode can be activated temporarily by entering HotCode 065380 immediately after switching the transmitter ON. The following display appears:

```
>MEASURING<  sf
Leakage measure
```

The main menu of the LEAKAGE mode is displayed (see chapter 8). The LEAKAGE mode is activated.

Note: This display appears only if the LEAKAGE transducer is connected with the transmitter.

Note: *If the following message appears after input of the HotCode to change into LEAKAGE mode, the LEAKAGE meter does not support any aircrafts:*

```
*      ONLY      *
Trouble shooter!
```

Only the volume flow can be measured in the Troubleshooter mode. No measurement of the leak rate is possible. If you want to use the LEAKAGE mode to measure the leak rate in hydraulic systems, consult FLEXIM.

If the LEAKAGE mode is activated temporarily, it will not be activated when the transmitter is switched OFF and ON again.

10.4 Troubleshooting Measurement

```
>MEASURING<  sf
Trouble shooter
```

The main menu shows that the device is in Troubleshooter mode. The Troubleshooting measurement can be started. Select the program branch MEASURING and press ENTER.

Note: *The main menu appears only if the LEAKAGE transducer is connected with the transmitter.*

If the transducer is not connected, the following display appears after the transmitter has been switched on:

```
>MEASURING<  sf
CONNECT SENSOR !
```

Connect the transducer to the transmitter. The measurement can only be started when the transducer is connected and the transmitter has been detected.

```
*LEAKAGE SENSOR*
*      DETECTED      *
```

The transducer has now been detected. The Troubleshooter mode can now be activated.

When the LEAKAGE transducer is detected, press ENTER.

```
5000psi aircraft
>NO<          yes
```

Select NO to display the pipe selection list for the 3000 psi (200 bar) hydraulic system.

Select YES to display the pipe selection list for the 5000 psi (350 bar) hydraulic system.

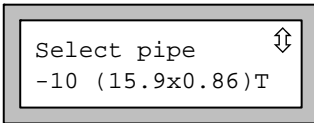

The pipe selection list will be displayed. Select the pipe type for measurement.

The following pipe types are available in the selection lists:

-4	(6.35x0.41)T
-6	(9.53x0.48)T
-8	(12.7x0.66)T
-10	(15.9x0.86)T
-12	(19.0x0.99)T
-16	(25.4x1.29)T
-6B	(9.53x0.89)T
-10B	(15.9x1.36)T

-4	(6.35x0.64)T
-6	(9.53x0.76)T
-8	(12.7x1.02)T
-10	(15.9x1.27)T
-12	(19.0x1.50)T
-16	(25.4x2.01)T

Confirm by pressing ENTER.

Information about the quality of the coupling between the LEAKAGE transducer and the pipe (C) and about the signal amplitude (S) is displayed.

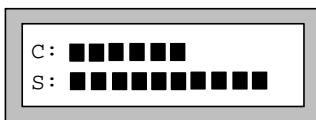

Press key to scroll on the upper line between the display of the bar graph of the signal amplitude (S), the bar graph of the quality of the signal (Q) and the display of the transit time (time) in microseconds.

If the signal is sufficient for measurement, the SIGNAL LED shows green. Confirm with ENTER to start the measurement.

If the signal is NOT sufficient for measurement, the SIGNAL LED shows red. In this case make sure that:

- enough coupling compound has been applied on the transducer
- there is no dirt between the transducer and the pipe.

If the SIGNAL LED still shows red, see chapter 13.

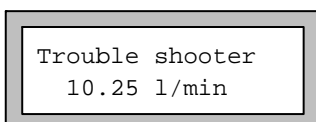

The measurement has been started. The measured volume flow is displayed.

During measurement, various measured values can be displayed on the LEKAGE meter.

- a) By scrolling on the second line of the display with key , the following values will be displayed:

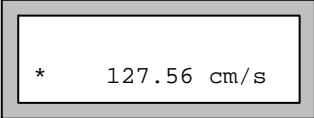

* 127.56 cm/s

- the flow velocity,

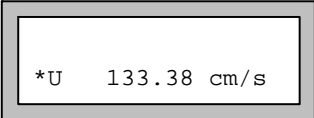

*U 133.38 cm/s

- the flow velocity without profile correction,

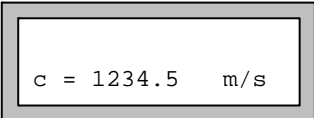

c = 1234.5 m/s

- the sound speed of the fluid.

- b) By scrolling on the first line of the display with key , the following values will be displayed:

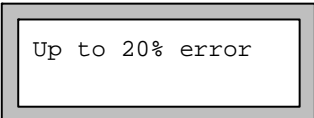

Up to 20% error

- a warning message that the estimated error could be up to 20%,

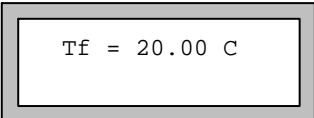

Tf = 20.00 C

- the temperature,

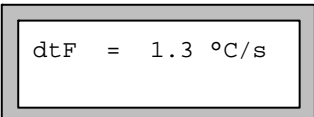

dtF = 1.3 °C/s

- the variation of the fluid temperature per time unit,

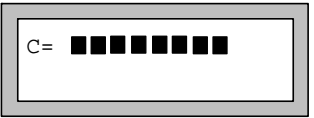

C= ■■■■■■■■

- the bar graph C for the quality of the coupling between the transducer and the pipe ,

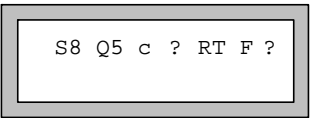

S8 Q5 c ? RT F ?

- the status line with information about the quality and the precision of the actual measurement (see Table 8.1).

Press BRK to stop the measurement and return to the main menu.

Equipment P/N:
610007AB

Issue: L

Ground Instruction Manual



11 Operator Misuse

This GSE / Tool is only designed for operating (e.g. Removal / Installation) in accordance with the AMM Task. Refer to the Aircraft Maintenance Manual (AMM):

A320 family

Maintenance Task:

29-00-00-280-001, Check of the Internal Leakage of the Green Hydraulic System

29-00-00-280-002, Check of the Internal Leakage of the Blue Hydraulic System

29-00-00-280-003, Check of the Internal Leakage of the Yellow Hydraulic System

A330/A340 family

Maintenance Task:

29-19-00-720-801, Check of the Internal Leakage of the Blue and Yellow Hydraulic Systems

29-19-00-720-802, Check of the Internal Leakage of the Green Hydraulic System

A350-900

Maintenance Task:

29-1X-XX-02001-340A-A, Functional Test to Monitor Internal Leak Rate of the Green and Yellow Hydraulic Systems

A380 VDHM

Maintenance Task:

27-54-00-720-803, Functional Test to Monitor Internal Leak Rate of the PCU Hydraulic Motors

12 GSE Handling in Accordance to the AMM

Any handling procedure with the GSE at A/C must be in accordance with the AMM Task. Refer to the Aircraft Maintenance Manual (AMM):

A320 family

Maintenance Task:

29-00-00-280-001, Check of the Internal Leakage of the Green Hydraulic System

29-00-00-280-002, Check of the Internal Leakage of the Blue Hydraulic System

29-00-00-280-003, Check of the Internal Leakage of the Yellow Hydraulic System

A330/A340 family

Maintenance Task:

29-19-00-720-801, Check of the Internal Leakage of the Blue and Yellow Hydraulic Systems

29-19-00-720-802, Check of the Internal Leakage of the Green Hydraulic System

Equipment P/N:
610007AB

Issue: L

Ground Instruction Manual



A350-900

Maintenance Task:

29-1X-XX-02001-340A-A, Functional Test to Monitor Internal Leak Rate of the Green and Yellow Hydraulic Systems

A380 VDHM

Maintenance Task:

27-54-00-720-803, Functional Test to Monitor Internal Leak Rate of the PCU Hydraulic Motors

13 Troubleshooting

Which of the followings describes the best your problem?

a) Problems with the measurement:

The display does not work at all or always goes out. Make sure that the correct voltage is available at the terminals of the instrument. The necessary voltage is indicated on the metal plate under the terminal strip where the power supply is connected. If the power supply is ok, the transducers or an internal component of the transmitter are defective. Consult FLEXIM.

b) The signal amplitude (S) is insufficient.

Measurement is impossible. Remove the transducer from the pipe and mount it on the pipe again.

c) The coupling quality (C) is insufficient.

Bad coupling. Check the correct position of the transducer on the pipe according to the AMM. Check correct mounting and coupling compound as described in section 7.2. If the "Signal" LED shows green, a measurement is possible.

d) The error message "System Error" is displayed:

Press BRK to call the main menu. If this happens several times, note the code displayed on the lower line of the display, write down in which situation the error occurred and contact FLEXIM.

e) The backlight of the display does not light on, but everything else works:

If no external power is connected switch on the light by pressing key .

The backlight is defective. Send the instrument to FLEXIM for repair. This problem has no influence on the other functions of the display.

f) The date and time displayed are wrong and measured values are deleted when the LEAKAGE meter is switched off:

The data backup battery must be replaced. Send the instrument to FLEXIM.

g) Measuring values substantially differ from the expected values.

Wrong checkpoint code. Make sure that the entered checkpoint code is correct. Refer to AMM.

If any problem appears which cannot be solved with the help of this chapter, please contact FLEXIM, giving a precise description of the problem.

Contact: FLEXIM GmbH
Boxberger Straße 4
D-12681 Berlin
Phone: +49 (30) 93 66 76 60
Fax: +49 (30) 93 66 76 80
E-Mail: flexim@flexim.de
www.flexim.de

Do not forget to specify the type, serial number and part number of your instrument.

Equipment P/N:
610007AB

Issue: L

Ground Instruction Manual





14 Spare Parts

Spare part	Part number
Firmware for A320 family	61007010-01
Firmware for A330/A340 family	61007030-01
Firmware for A350-900	61007040-01
Firmware for A380 VDHM	61007050-00
Transmitter GST 6108	6100110
Power cord Europe incl. universal adapter	6106220
Power supply and battery charging unit, 110-220 V AC without power cord	6106221
User's manual English	61076044
Fastening strap	6110387
Leakage transducer FS3N7	6110481
Coupling compound tube, 100 g	6120501
Set of rechargeable batteries, 6 V / 5 Ah	6120601
Carrying case	6120701
Data transfer kit	6122447

Spare part	Part number
Training course on site, one day, max 4 persons (travelling costs and accommodation are billed separately)	610080
Training course in Berlin, one day, max 4 persons	610081
Calibration and adjusting of a LEAKAGE transducer with GST 6108	610090

Equipment P/N:
610007AB

Issue: L

Ground Instruction Manual



Equipment P/N:
610007AB

Issue: L

Ground Instruction Manual



Certificate

Equipment P/N:
610007AB

Issue: L

Ground Instruction Manual



We,

FLEXIM Flexible Industriemesstechnik GmbH
Boxberger Straße 4
12681 Berlin
Germany,



declare under our sole responsibility that the ultrasonic LEAKAGE meter

GST 6108

to which this declaration relates is in conformity with the following EU directives:

- EMC Directive 2014/30/EU for Electromagnetic Compatibility
- Low Voltage Directive 2014/35/EU for Electrical Safety

The ultrasonic LEAKAGE meter is in conformity with the following European standards when used with the LEAKAGE transducer and accessories:

EU directive	Class	Standard	Description
EMC Directive	EMC Requirement	EN 61326-1:2013	Electrical equipment for measurement, control and laboratory use – EMC requirements – General requirements
	- Immunity	EN 61326-1:2013	Electrical equipment for continuous, unattended operation intended to be used in an industrial electromagnetic environment
		EN 61000-4-2:2009	Electromagnetic compatibility (EMC) – Testing and measurement techniques – Electrostatic discharge immunity test
		EN 61000-4-3:2006 + A1:2008 + A2:2010	Electromagnetic compatibility (EMC) – Testing and measurement techniques – Radiated, radio-frequency, electromagnetic field immunity test
		EN 61000-4-4:2004 + A1:2010	Electromagnetic compatibility (EMC) – Testing and measurement techniques – Electrical fast transient/burst immunity test
		EN 61000-4-5:2006	Electromagnetic compatibility (EMC) – Testing and measurement techniques – Surge immunity test
		EN 61000-4-6:2009	Electromagnetic compatibility (EMC) – Testing and measurement techniques – Immunity to conducted disturbances, induced by radio-frequency fields
	- Emission	EN 61326-1:2013	Electrical equipment class A
		EN 55011:2009 + A1:2010	Industrial, scientific and medical equipment – Radio-frequency disturbance characteristics – Limits and methods of measurement

(continuation on verso)

EU directive	Class	Standard	Description
Low Voltage Directive	Equipment Safety Requirement	EN 61010-1:2010	Safety requirements for electrical equipment for measurement, control, and laboratory use – General requirements
		EN 61010-2-030:2010	Safety requirements for electrical equipment for measurement, control, and laboratory use – Particular requirements for testing and measuring circuits

The installation, operating and safety instructions have to be observed!

Berlin, 2017-12-11



Dipl.-Ing. Jens Hilpert
Managing Director



Index

<p>Battery29, 42 Charging the battery42</p> <p>Calibration15 Recalibration15</p> <p>Carrying case13 Greet and accessories13</p> <p>Cleaning15</p> <p>Contrast45</p> <p>Date44</p> <p>Deleting measured values42</p> <p>Display28 Main menu28</p> <p>Input35 Parameter35</p> <p>Input mode46</p> <p>Instrument information47</p> <p>Keypad25</p> <p>LEAKAGE transducer20, 21, 31 Connection of the LEAKAGE transducer to the transmitter.....31 Mounting of the LEAKAGE transducer on the pipe31 Outer dimensions21</p> <p>LED29 Battery29 Signal29 Status29</p>	<p>Main menu28 Program branches28</p> <p>Maintenance15</p> <p>Measuring principle10</p> <p>Mounting23</p> <p>Output format45</p> <p>Output of the measured values41</p> <p>Permanent Troubleshooter Mode48</p> <p>Scope of delivery13</p> <p>Serial number47</p> <p>Specifications17</p> <p>Storage conditions15</p> <p>Temperature probe22 LEAKAGE transducer22</p> <p>Temporary Troubleshooter Mode49, 50</p> <p>Time44</p> <p>Transmitter19, 20, 25, 28, 35 Assembly19 Display28 Keypad25 Outer dimensions20 Switching on35</p> <p>Transport conditions14</p> <p>Troubleshooter Mode48 Permanently48 Temporarily49, 50</p> <p>Troubleshooting Measurement50</p> <p>Units46 Selection46</p>
--	---